

HATL03-1RDOB

1 Relay Development HAT for Raspberry Pi

I. Short description

HATL03-1RDOB is universal and very functional board. It is specifically designed for MaticBox Case compatibility and is made for people who want to use the Raspberry Pi for automation projects in home or industrial environment.



II. Included

- PCB board -1pc.
- Female Connectors for JP3, JP5, JP6 -3pcs.
- Pitch terminal – 12pcs.

III. Elements and Features

Relay

The board has 1 Relay with the possibility of switching up to 250V AC and max current up to 6A.

LED diode

Two-color LED – red/green. If combined with frequency switching - yellow.

Buzzer

There is a buzzer for sound signaling, **without its own sound generator**. It is connected to the Raspberry Pi pin with built-in PWM with which the client can choose the and sounds of the buzzer. The control signal of the buzzer always needs to be modulated.

Button

For service needs. Additionally button extension can be added (ordered separately). With the button extension, the button can be pressed with pointy object (such as pen) trough the automation cover of MaticBox.

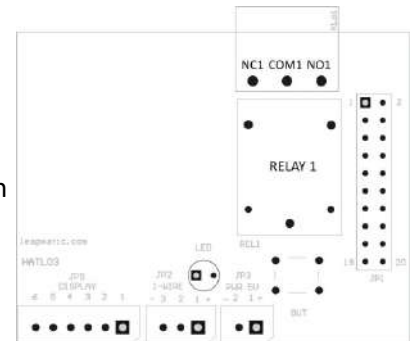

Top Connectors

I2C port – JP5

For infrared port or other universal application – JP6

For external 5V power supply - JP3

IV. IMPORTANT GUIDELINES FOR HAT MANAGEMENT

Guidelines for initial startup of software used for HAT mangament (Node red, other software or custom code)

- All GPOs that control outputs such as relays, LED, buzzer, InfraRed Output, should be defined as outputs with the value "0"
- To use the Button You need to switch on the pull-up resistor function for this Input
- The Buzzer is connected to the Raspberry Pi pin with built-in PWM. The frequency should not be less than 1kHz. It is desirable that the fill factor is not more than 10%.
- To all I/O can be connected a button to ground.
- *Outputs are Open Collector to ground. $I_{max} = 100\text{ mA}$; $U_{max} = 16\text{ V}$

V. How to unmount the board

(*visuallisations may not be made with the exact model HAT, but they represent the same-dimentional HAT)

The mounting of HATL03 is easy. You just place it on top of the pins and push it down. The unmounting is easy as well but you need to be careful with all 20 pins underneath. That's why we added in this document a quick and easy way how to unmount the board.

1. On the both corners we designed a special space where you can insert a little screw driver.
2. Then put a screw driver into the upper hole and lift carefully the HAT
3. Repeat the same with the other side
4. Lift the board from the case

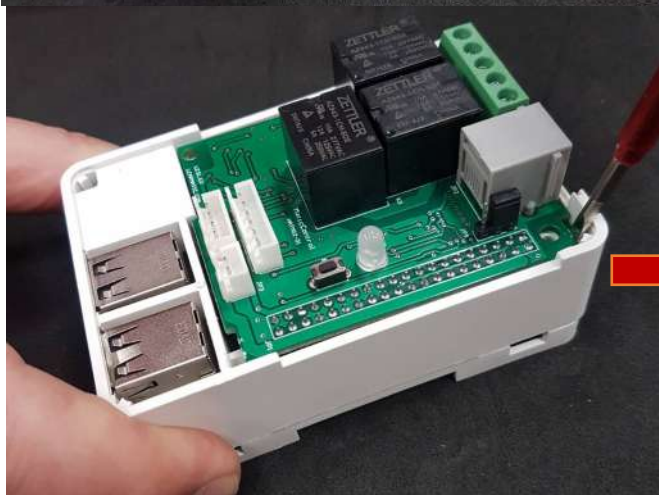
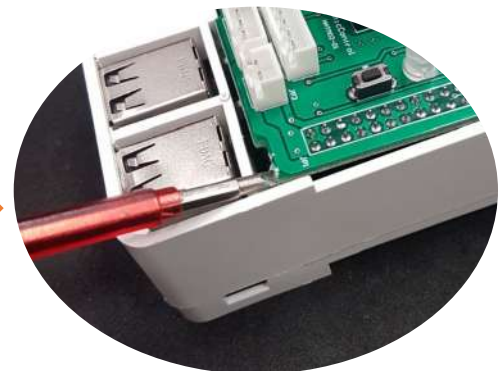
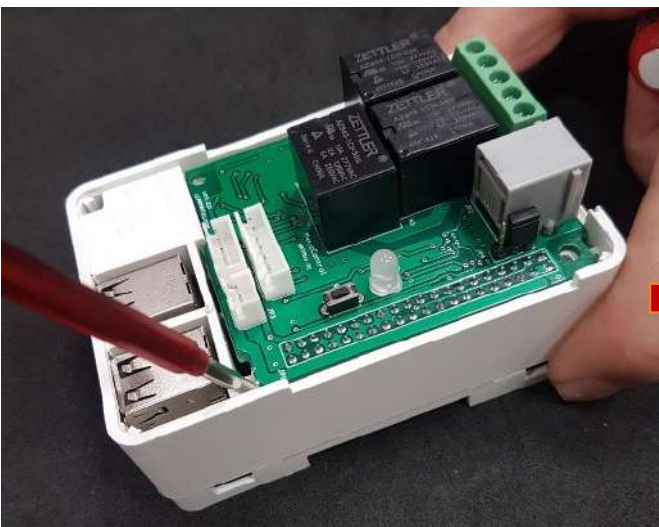
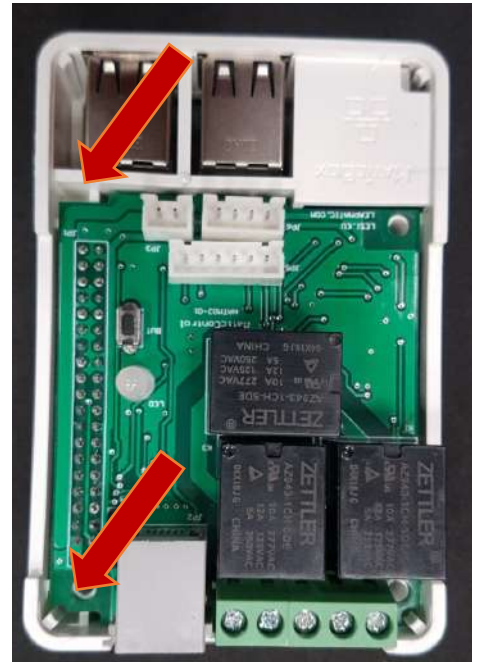

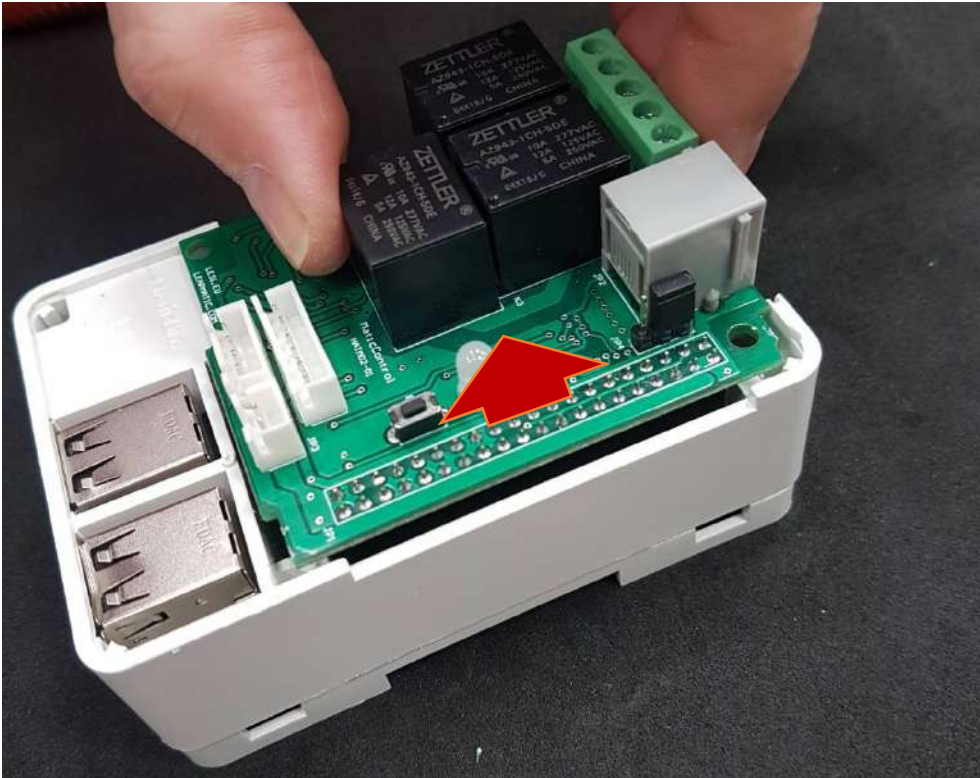

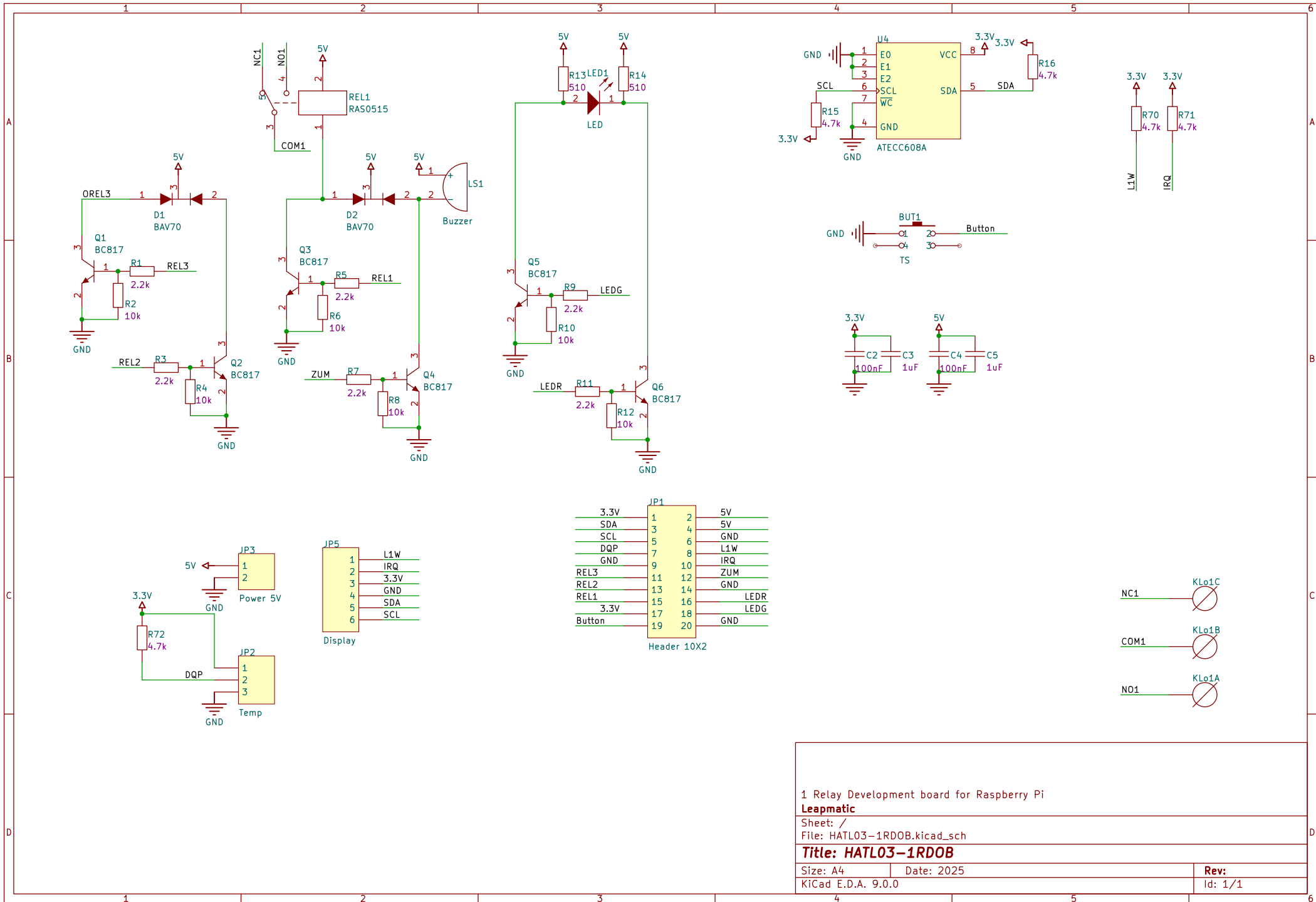

1 Relay Development board for Raspberry Pi

Leapmatic

Sheet: /

File: HATL03-1RDOB.kicad_sch

Title: HATL03-1RDOB

Size: A4

Date: 2025

KiCad E.D.A. 9.0.0

Rev:

Id: 1/1